

# LB478A & LB479A CW and Pulse (Modulation) USB PowerSensor+™

Data Sheet

## Key PowerSensor+™ Specifications

10 MHz to 8 GHz (functional to 10 GHz)

LB479A: -60 dBm to +20 dBm

LB478A: -35 dBm to +20 dBm

1.95% Total Error\*

1.09:1 VSWR (-27 dB Return Loss)

\* Measuring a well matched DUT (-20 dBm @ 1 GHz)

## Key PowerSensor+™ Capability

Pulse (Modulation) Power Measurements: *Duty Cycle, Measured Pulse Power, Peak Power, Crest Factor*

CW and Average Measurements: *Average Power, Duty Cycle-Corrected Pulse Power, Data Logging*

## Description

The PowerSensor+™ is an easy to use high performance, general purpose and pulse (modulation) power sensor. High speed measurements and temperature compensated accuracy provide superior in-class performance. These instruments are suitable for making real time scalar analyzer measurements with 2,000 readings per second.

Get up and running quickly with the CW and Pulse power meter panels. Easily integrate the power sensors into Lab View, C, VB and other programming environments using the supplied drivers and programming examples.

Integration and usability are further simplified because calibration and zeroing are not required before use and, you have the flexibility of selecting from a variety of connector types including SMA, N, and 3.5 mm (male or female).

Unlike other CW sensors, the LB478A and LB479A can make a variety of Peak and Pulse Power measurements often found in power measurement solutions costing well over \$10,000.

## Features

- Superior in-class price
- Superior in-class performance
- Fast - 10 to 100 times faster than competitive sensors
- Compact - 1/10 the volume of competitive sensors
- Ruggedized USB connector - does not fatigue or break like competitive sensors
- Trigger on RF input levels
- Fully calibrated over temperature
- Offered with 30 day return policy

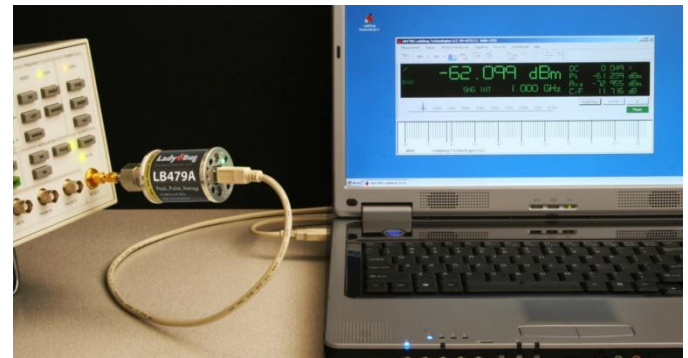

Setup for One Sensor Measurements

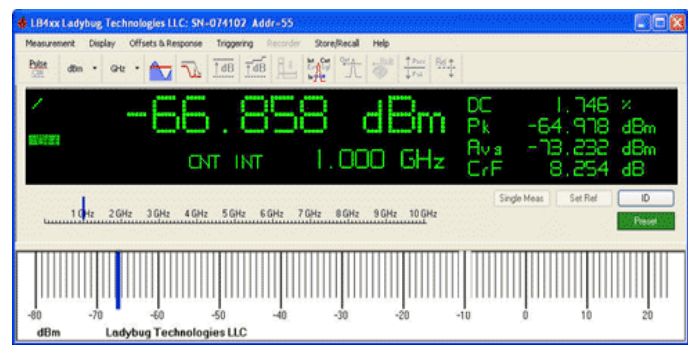

Pulse Power Panel

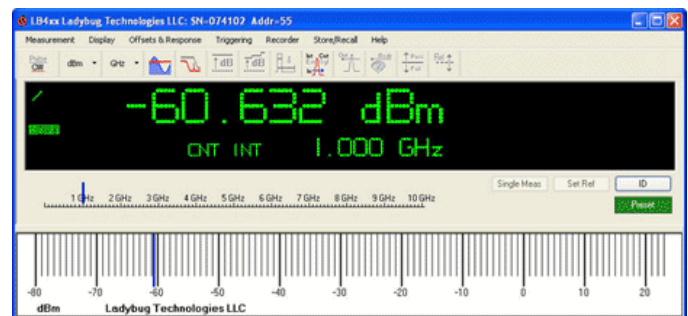

CW Power Panel

## Applications

- General purpose scalar measurements
- General average and pulse RF and microwave power measurements requiring leading edge accuracy:
- CW & pulsed signals
- Narrow and wide band signals: CDMA, W-CDMA, QAM, OFDM, GSM, TDMA, QPSK, FSK, AM, FM, etc.
- Recorders, power monitoring, and ALC loops
- Research & development, and manufacturing
- Maintenance, repair, installation, and service
- Radar, wireless, satellite, radio links, etc.

# LB478A & LB479A CW and Pulse (Modulation) USB PowerSensor+™

Data Sheet

## Product Comparison

Model No. and Description	SWR <sup>1</sup>	Dynamic Range	CW & Pulse	Pulse Profiling
LB478A CW PowerSensor+	1.15:1	-35 to +20 dBm	Yes	No (See LB480A)
LB479A CW Wide Dynamic Range PowerSensor+	1.09:1	-60 to +20 dBm	Yes	No (See LB480A)

1-For SMA connector see match data for other connectors

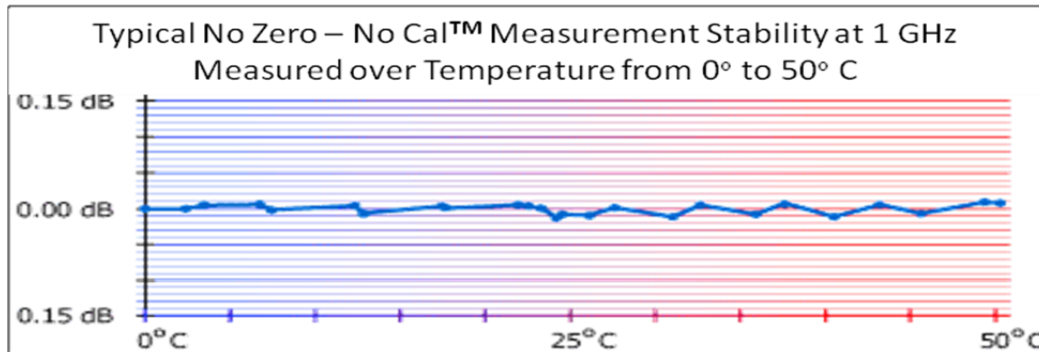

## LB478A & LB479A PowerSensor+™ Specifications

Parameter	LB479A	LB478A
<b>Frequency Range</b>	10 MHz to 8 GHz (functional to 10 GHz)	
<b>Dynamic Range</b>		
10 MHz to 6 GHz	-60 dBm to +20 dBm	-35 dBm to +20 dBm
6 GHz to 8 GHz	-50 dBm to +20 dBm	-30 dBm to +20 dBm
<b>Accuracy</b>	Total Error (RSS) = $\sqrt{(Mm^2 + CF^2 + L^2 + N^2 + T^2 + Z^2)}$ <i>Note 1</i>	
<b>Calibration Factor</b> (Type N)	NIST traceable	
10 MHz to 100 MHz	7.0%	
100 MHz to 500 MHz	4.0%	
500 MHz to 8 GHz	1.7%	
(SMA)		
10 MHz to 100 MHz	7.0%	
100 MHz to 500 MHz	4.0%	
500 MHz to 8 GHz	2.5%	
(3.5 mm)		
10 MHz to 100 MHz	7.0%	
100 MHz to 500 MHz	4.0%	
500 MHz to 8 GHz	4.0%	
<b>Linearity</b> <i>Note 3</i>		
(100 MHz to 2 GHz)		
+15 to +20 dBm	7.0%	
+10 to +15 dBm	5.0%	
-60 to +10 dBm	3.0%	
(2 GHz to 8 GHz)		
+15 to +20 dBm	5.0%	
+10 to +15 dBm	3.0%	
-60 to +10 dBm	2.0%	

# LB478A & LB479A CW and Pulse (Modulation) USB PowerSensor+™

## Data Sheet

Parameter	LB479A	LB478A
<b>Accuracy (continued)</b>		
<b>Noise</b>	1 second integration	
( -30 to +20 dBm)		
10 MHz - 100 MHz	0.22%	
100 MHz - 6 GHz	0.02%	
6 GHz - 8 GHz	0.04%	
( -50 to -30 dBm)		
10 MHz - 100 MHz	0.22%	
100 MHz - 6 GHz	0.04%	
6 GHz - 8 GHz	0.15%	
(-60 to -50 dBm)		
10 MHz - 100 MHz	0.44%	
100 MHz - 6 GHz	0.11%	
<b>Zero Offset</b> <i>Note 3</i>	[[ (0.35 nW @ 25°C) +  ΔT  x (0.025 nW / °C) ] ± 0.005 nW / month] <i>Note 2</i>	
<b>Match</b> <i>Note 4</i>		
(Type N)		
10 MHz to 8 GHz	1.15:1 VSWR (23 dB Return Loss)	1.20:1 VSWR (21 dB Return Loss)
(SMA)		
10 MHz to 8 GHz	1.09:1 VSWR (27 dB Return Loss)	1.15:1 VSWR (23 dB Return Loss)
(3.5 mm)		
10 MHz to 8 GHz	1.09:1 VSWR (27 dB Return Loss)	1.15:1 VSWR (23 dB Return Loss)
<b>Temperature (°C)</b>		
40 - 50	1.00% (plus 1%, 0 dBm to 10 dBm; plus 3%, 10 dBm to 20 dBm)	
30 - 40	0.75% (plus 1%, 0 dBm to 10 dBm; plus 3%, 10 dBm to 20 dBm)	
20 - 30	0.00%	
10 - 20	0.75% (plus 1%, 0 dBm to 10 dBm; plus 3%, 10 dBm to 20 dBm)	
0 - 10	1.00% (plus 1%, 0 dBm to 10 dBm; plus 3%, 10 dBm to 20 dBm)	
<b>Maximum Average Power</b>	+20 dBm (100 mW)	
Damage Level	+23 dBm (200 mW)	
<b>Maximum Pulse Power</b>	+20 dBm (100 mW)	
Damage Level	+23 dBm (200 mW)	
<b>Maximum Peak-to-Average Ratio</b>		
100 MHz to 6 GHz	80 dB	55 dB
6 GHz to 8 GHz	70 dB	50 dB
<b>Video Bandwidth</b>	10 MHz	
<b>Time Base</b>	+/- 50 ppm	
<b>Effective Sample Rate</b>	48 MS/second	
<b>Measurements</b>	2000/second	
<b>Pulse (Modulation) Power Measurements</b>	Duty Cycle, Measured Pulse Power, Peak Power, Crest Factor (Peak-to-Average Ratio)	
<b>Average Power Measurements</b>	Average Power, Duty Cycle-Corrected Pulse Power, Data Logging	

<sup>1</sup> Error term definitions: Mm (Mismatch); CF (Cal Factor); N (Noise); L (Linearity); T (Temperature); Z (Zero Offset). All error terms are converted to percentages for RSS calculation.

<sup>2</sup> Use the following formula to determine Zero Offset error (%):  $Z = (\text{Zero Offset Power} / \text{Measured Power})100$ .

<sup>3</sup> Linearity & Zero Offset are measured as a combined specification, LadyBug sensors do not require zeroing or reference calibration before use.

<sup>4</sup> The sensor must be powered (USB connected to a PC) for accurate match testing.

# LB478A & LB479A CW and Pulse (Modulation) USB PowerSensor+™

## Data Sheet

Parameter	LB479A	LB478A
<b>Trigger</b>	Option 003	
Resolution	2 us	
Modes (GUI)	Single, Continuous	
Source	External	
Input	TTL compatible, rising or falling edge	
V <sub>IH</sub> , minimum high-level input	2.0 V at +/- 10 uA	
V <sub>IL</sub> , maximum low-level input	0.8 V at +/- 10 uA	
Connector type	SMB male (shared with recorder output)	
Absolute maximum levels	5.5 V maximum, -0.5 V minimum	
Output	TTL compatible, rising or falling edge	
V <sub>OH</sub> , minimum high-level output	4.6 V at 1 mA	
V <sub>OL</sub> , maximum low-level output	0.8 V at -1 mA	
Connector type	SMB male	
Absolute maximum levels	5.5 V maximum, -0.5 V minimum	
<b>Recorder Out</b>	Option 001	
Range		
Operating	0 to 1 V typical	
Maximum output	5 V, if in trigger mode (option 003)	
Output impedance	1 K ohm typical	
Sensitivity		
Scale	Linear or dB, factory default to Linear	
Full Scale Value	User settable, factory default to Linear	
Connector type	SMB male (shared with trigger input)	
<b>Recommended Calibration Cycle</b>	1 year	
<b>Environment, operating</b>		
Temperature	0 °C to 55 °C	
Humidity	15% - 95% non-condensing	
Altitude	10,000 feet (3,000 meters)	
<b>Environment, storage</b>		
Temperature	-25 °C to 85 °C	
Humidity	15% to 95% non-condensing	
Altitude	50,000 feet (15,000 meters)	
<b>Physical</b>		
Weight	2.9 oz (82 g), plus connector weight	
Size	1.6" (40 mm) diameter by 2.3" (57 mm) long plus connector length	

**LB478A & LB479A CW and Pulse (Modulation) USB PowerSensor+™**  
Data Sheet

**LB4XXA PowerSensor+ Outline Drawings**  
(dimensions are inches +/- 0.01)

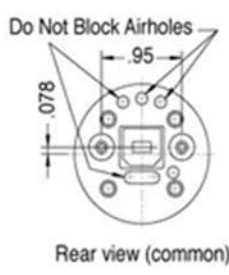
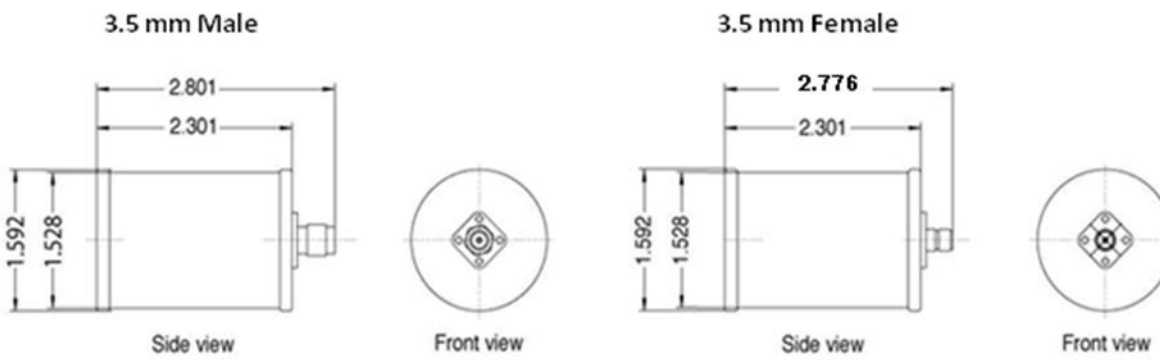
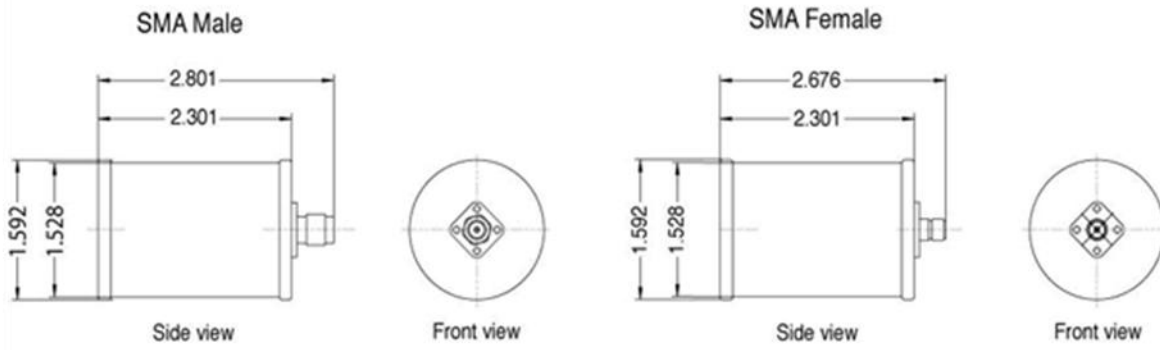
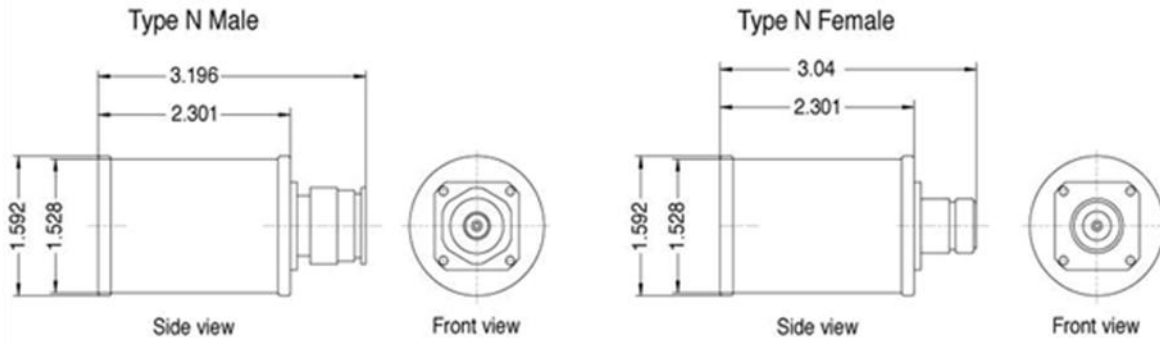

## **LB478A & LB479A CW and Pulse (Modulation) USB PowerSensor+™**

### **Data Sheet**

Revisions to data sheet by date:

03/25/09:

1. Add mechanical outline drawings.
2. Add revision page.
3. Change descriptor "Pulse (Peak) Power" to "Pulse (Modulation) Power".
4. Accuracy updates: temperature; add Zero Offset.

06/01/12

1. Add 3.5 mm connectors
2. Add temp sensitivity graph

11/09/16

1. Add SWR footnote under product comparison

04/25/21

1. Change photos and address

10/21/21

1. Add match note 4 in specifications

9/24/25

1. Copied measurement ranges to Key Specifications on front page